

Temperature Measurement

Transmitters for field mounting

SITRANS TF280 WirelessHART

Overview



SITRANS TF280 for flexible and cost-effective temperature measurements

- Supports the WirelessHART standard (HART V 7.1)
- Very high security level for wireless data transmission
- Built-in local user interface (LUI) with 3-button operation
- Optimum representation and readability using graphical display (104 x 80 pixels) with integrated backlight
- Stand-by (deep sleep phase) mode can be turned on and off with push of a button
- Battery power supply
- Battery life time up to 5 years
- Extend battery life time with HART modem interface which can be switch off
- Optimized power consumption through new design, and increase in battery life time
- Simple configuration thanks to SIMATIC PDM
- Housing meets IP65 degree of protection
- Supports all Pt100 sensors as per IEC 751/DIN EN 60751

Benefits

The SITRANS TF280 is a temperature transmitter that features WirelessHART as the standard communication interface.

Also available is a wired interface to connect a HART modem:

- Flexible temperature measurement
- Save costs on wiring at difficult installation conditions. Wireless technology offers cost advantages in cases where extensive wiring costs would normally apply.
- It enables additional hitherto unfeasible measuring points, particularly for monitoring purposes
- Easy installation also on moveable equipment parts
- Enables cost-effective temporary measurements, for example for process optimizations.
- Optimum solution in addition to wired communication and for system solutions in process automation

Application

The SITRANS TF280 is a WirelessHART field device for temperature measurement with a Pt100 sensor.

This sensor can be installed directly on the field device, or connected at an offset with a cable connection. On the wireless communication side, the transmitter supports the WirelessHART standard. A HART modem can be connected to the transmitter particularly for initial parameterization. Alternatively the device can be commissioned comfortably by means of the local push-buttons w/o any additional handset devices.

It can be used in all industries and applications in non-explosive areas.

Design

The SITRANS TF280 has a robust aluminum enclosure and is suitable for outside use. It conforms with the IP65 safety class.

The operation temperature range is -40 to +80 °C (-40 to +176 °F). Power supply is provided through an integrated battery, which is available as an accessory. The device is only approved for operation with this battery.

The antenna features a rotatable joint which can be used for directional alignment. Wireless signals can thus be optimally received and transmitted.

A special highlight is the possibility to operate directly on the device with 3 push buttons. It perfectly matches the strategy of all new Siemens field devices.

Using the device's push buttons, it is easy to turn the HART modem interface of the device on and off. The device can be put to passive status and reactivated at any time. This helps to extend the life time of the battery.

The SITRANS TF280 transmitter features a cable gland or a Pt100 sensor including protective piping.

Function

The SITRANS TF280 can join to a WirelessHART network. It can be parameterized and operated through this network. Measured process values are transmitted via the network to the SIEMENS IE/WSN-PA LINK.

Field device data received by the IE/WSN-PA LINK is transmitted to the connected systems, for example the process control system SIMATIC PCS 7. For an introduction of WirelessHART, please see the FI 01 catalogue Sec. 9 or www.siemens.com/wirelesshart.

Detailed information on IE/WSN-PA LINK can be found in the FI 01 catalogue Sec. 9 or www.siemens.com/wirelesshart.

Integration

Connecting to SIMATIC PCS 7

The integration of field devices in SIMATIC PCS 7 and other process control systems can be now done seamlessly and cost-effectively with wireless technology, especially in situations where high wiring costs may be expected. Of particular interest are measuring points which are to be added and for which no wiring is available.

Where larger distances between the IE/WSN-PA LINK and control systems need to be overcome, this connection can also be implemented on a wireless and cost-effective basis using the SCALANCE W series of products. Siemens WirelessHART devices operate with optimum coexistence to SCALANCE W family products.

Temperature Measurement

Transmitters for field mounting

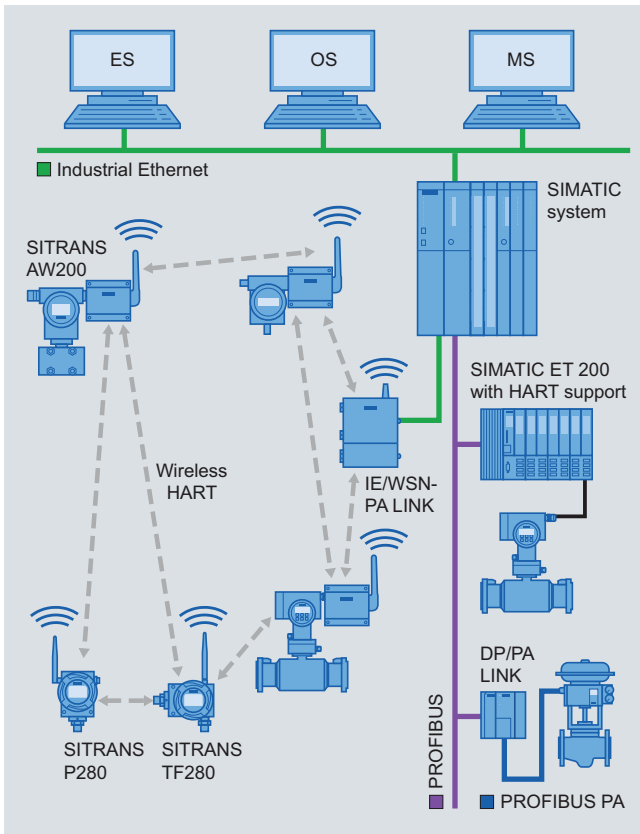
SITRANS TF280
WirelessHART

Integration of a meshed network into SIMATIC PCS 7

Configuration

Configuration of the SITRANS TF280 transmitter may be carried out as follows:

- Initial commissioning for the SITRANS TF280 with SIMATIC PDM is generally carried out via a HART modem or the integrated local user interface, since the network ID and join Key must be set up on the device before it can be accepted and integrated into the WirelessHART network.
- Once it is integrated into the network, the device can be conveniently operated with the WirelessHART network or onsite with a HART modem or via the local user interface.

Technical specifications

The SITRANS TF280 can be mechanically installed in two ways:

- Direct at the measuring point with a M20x1.5 thread. A connection to other threads can be done via the adapter.
- Remotely from the Pt100 sensor, which is connected to the transmitter via a cable.

The data in the following table refer to the transmitter only excluding a connected sensor, except as noted otherwise.

Input

Sensor

- Sensor type Pt100 as per IEC 751/DIN EN 60751¹⁾
- Connection Two, three or four-wire system
- Measuring range -200 ... +850 °C (-328 ... 1560 °F)

Cable length SITRANS TF280 and Pt100 sensor element

≤ 3 m

Measuring accuracy²⁾

Accuracy

< 0.04 % of the measured value

Long-term drift

< 0.035 % of the measuring range in first year

Ambient temperature effect

max. 0.1 °C/10 K

Rated conditions

Ambient temperature

-40 ... +80 °C (-40 ... +176 °F)

Storage temperature

-40 ... +85 °C (-40 ... +185 °F)

Relative humidity

< 95%

Climatic class

4K4H in accordance with EN 60721-3-4 (stationary use at locations not protected against weather)

Degree of protection

IP65/NEMA 4

Max. permissible temperature at transmitter for directly mounted Pt100

80 °C (176 °F)

Design

Enclosure

Die-cast aluminum

Shock resistance

in accordance with DIN EN 60068-2-29 / 03.95

Resistance to vibration

DIN EN 60068-2-6/12.07
20 ≤ f ≤ 2000 Hz
0.01 g²/Hz

Weight

- without battery

1.5 kg (3.3 lb)

- with battery

1.6 kg (3.5 lb)

Dimensions (W x H x D)

See "Dimensional drawing"

Thread for cable gland/ sensor connection

M20x1.5
other threads via adapter

Cable between transmitter and sensor element

≤ 3 m für two-, three- or four-wire connections

Cable resistance < 1 Ω (setting range in mΩ 0...9999)

Sensor break

Recognized

Temperature Measurement

Transmitters for field mounting

SITRANS TF280 WirelessHART

Displays and controls	
Display (with illumination)	
• Size of display	104 x 80 pixels
• Number of digits	Adjustable
• Number of spaces after comma	Adjustable
Setting options	<ul style="list-style-type: none"> • on site with 3 push buttons • with SIMATIC PDM or HART Communicator
Auxiliary power	
Battery	3.6 V DC
Communication	
Wireless standard	WirelessHART V7.1 conforming
Transmission frequency band	2.4 GHz (ISM-Band)
Range under reference conditions	Up to 250 m (line of sight) in outside areas Up to 50 m (greatly dependent on obstacles) in Inside areas
Communication interfaces	<ul style="list-style-type: none"> • HART communication with HART modem • WirelessHART
Certificates and approvals	
Wireless communication approvals	R&TTE FCC
Classification according to pressure equipment directive (PED 97/23/EC)	This device does not fall under the pressure equipment directive

- 1) Pre-mounted Pt100: Class A (maximum MES: $0.15 + 0.002 \cdot |t|$ °C)
- 2) Calculation for errors:
 Probable total error = $\sqrt{\text{MES}^2 + \text{AET}^2 + \text{LTD}^2 + \text{ATE}^2}$
 Max. error = MES + AET + LTD + ATE
 |t|: Absolut value of measured temperature
 MES: Measurement error of sensor
 AET: Accuracy error transmitter
 LTD: Long term drift
 ATE: Ambient temperature drift

Selection and Ordering data	Order No.
SITRANS TF280 WirelessHART Temperature transmitter ▶ D)	7MP1110 -
(Required battery not included with delivery, see accessories)	0A - 00
Connections/cable entry	
Cable gland M20x1.5 ¹⁾ Sensor pipe with Pt100, G½" male thread, pre-mounted and connected	C D
Display	1
Enclosure	1
Explosion protection	A
Antenna	A
Further designs	Order code
Please add "-Z" to Order No. and specify Order code(s) and plain text.	
Measuring point number (TAG Nr.) max. 16 digits entered in plain text Y15:	Y15
Measuring point message max. 27 characters entered in plain text: Y16:	Y16
Accessories	Order No.
Lithium battery for SITRANS TF280/P280 ▶ D)	7MP1990-0AA00
Mounting bracket, steel	7MF4997-1AC
Mounting bracket, stainless steel ▶	7MF4997-1AJ
Cover, die-cast aluminum, without window ▶ F)	7MF4997-1BB
Cover, die-cast aluminum, with window F)	7MF4997-1BE
Thread adapter M20x1.5 (male thread) on ½-14 NP (female thread) ▶	7MP1990-0BA00
Thread adapter M20x1.5 (male thread) on G½B (female thread) ▶	7MP1990-0BB00
IE/WSN-PA Link	see Sec. 9
HART modem with RS232 interface ▶ D)	7MF4997-1DA
HART modem with USB interface ▶	7MF4997-1DB
SIMATIC PDM	see Sec. 9
▶ Available ex stock	

1) Please order sensor separately.

D) Subject to export regulations AL:N, ECCN: EAR99H.

F) Subject to export regulations AL:9I999, ECCN: N.

Dimensional drawings

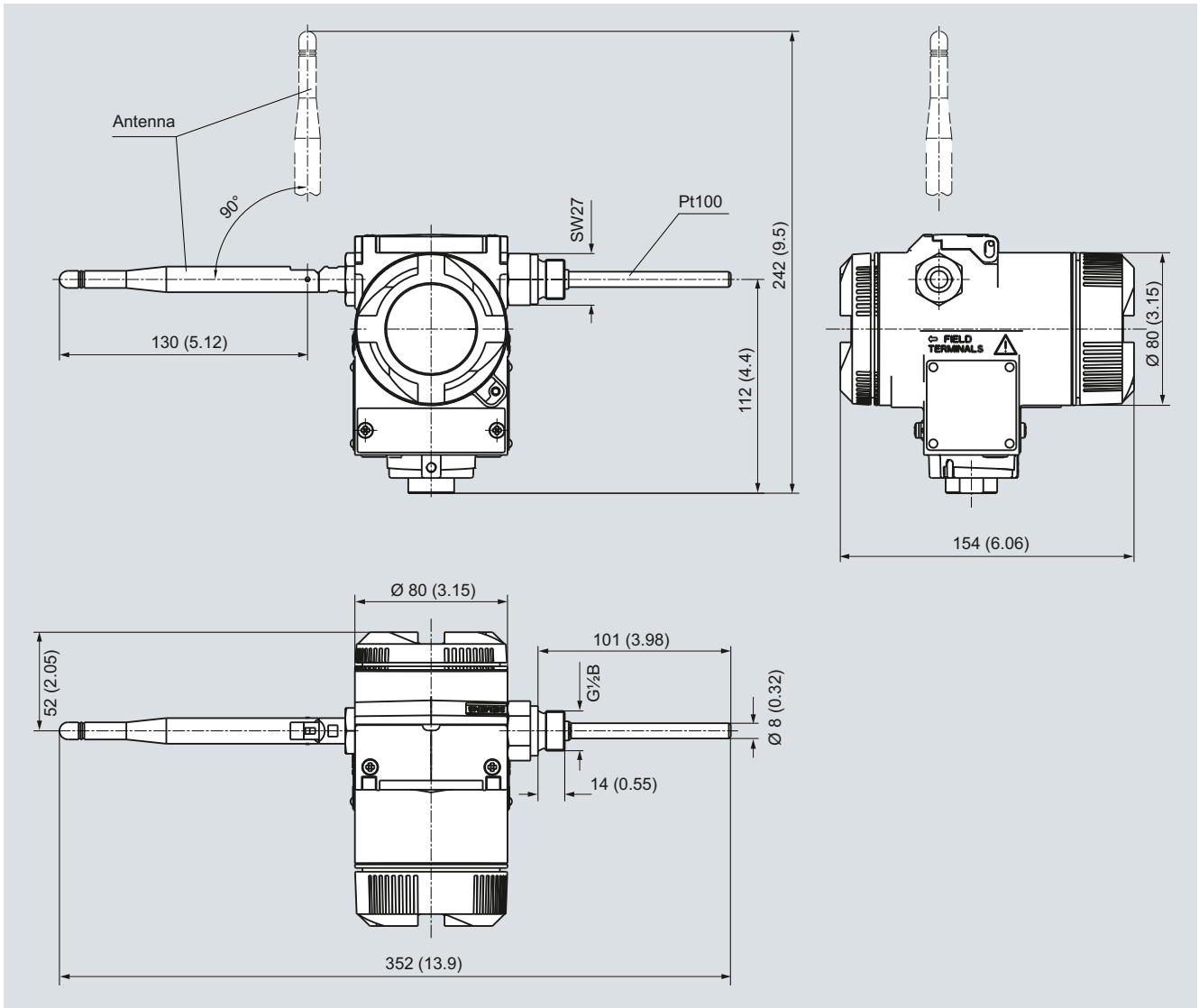

SITRANS TF280 WirelessHART temperature transmitter with Pt100, dimensions in mm (inch). Please see the dimensional drawing of the mounting bracket on page 2/146.

Temperature Measurement Transmitters for field mounting

SITRANS TF280 WirelessHART

3

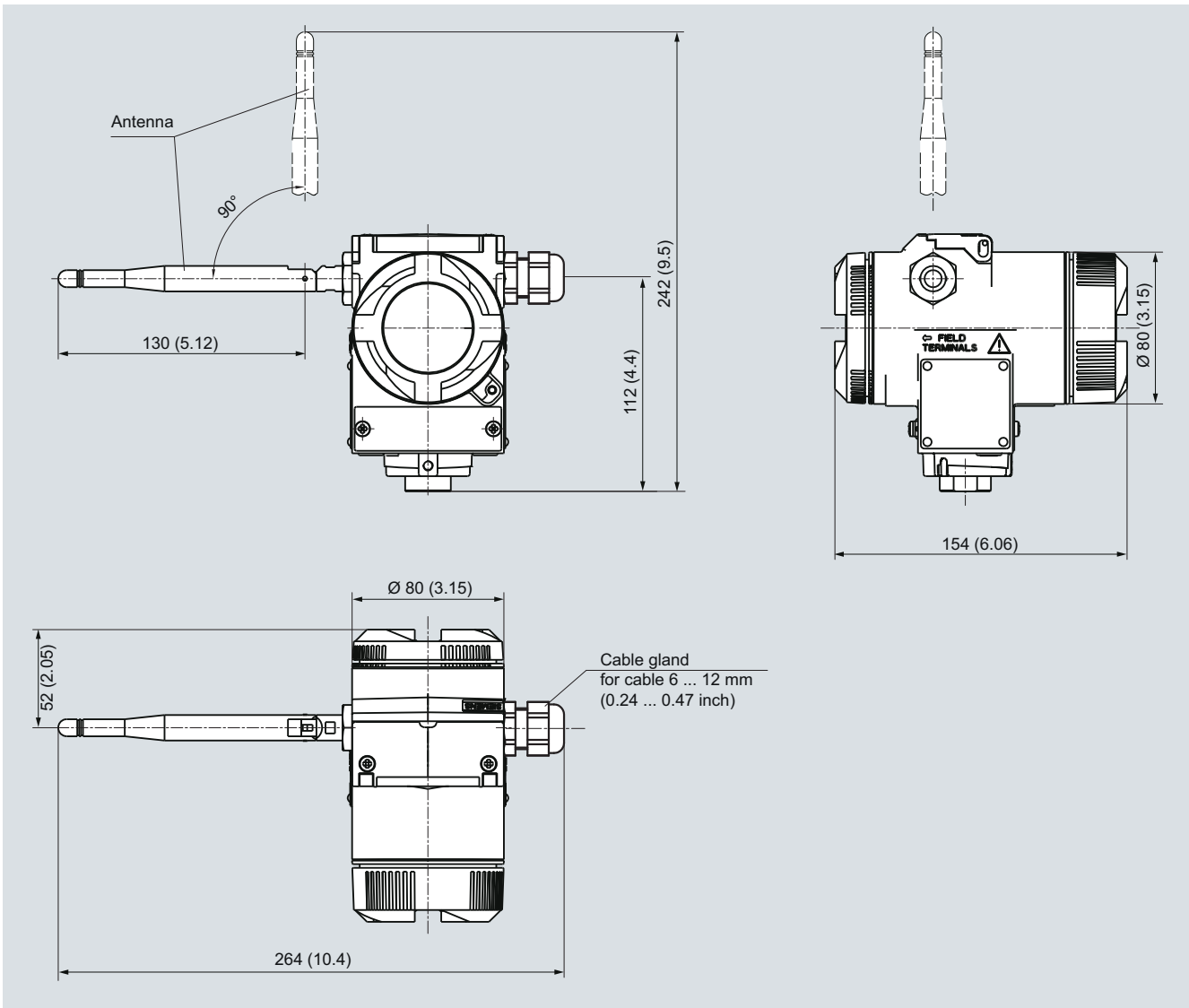

SITRANS TF280 WirelessHART temperature transmitter, dimensions in mm (inch)
 Please see the dimensional drawing of the mounting bracket on page 2/146.